

lr.products)

LR CONVERTING PERIPHERAL PRODUCTS, SL

**AUTOMATIC SOLVENTLESS
ADHESIVE MIXER
AND METERING
UNIT FOR LAMINATION**

- Accurate and reliable
- Production control
- Automatic g/m² calculations
- "On the fly" ratio changes
- Production data reports
- Maintenance trouble-free
- Several automatic refilling options



lr.products)

www.lrproducts.net

Poligono Pont Xetmar
Calle F #28 ES17844 Cornellà de Terri
Girona - Spain

T +34 972 59 64 35 / F +34 972 59 44 68
info@lrproducts.net

**LR PERIPHERAL
CONVERTING PRODUCTS**

- Ink viscosity controls
- Automatic ink pH regulation
- Ink temperature control
- Solventless mixers
- Monocomponent metering
- Solvent based mixers
- Automatic flexo wash-up units

www.3denou.com

bi-2 mixer

SOLVENTLESS ADHESIVES MIXING EQUIPMENT

CNC gear pumping technology.
More than 400 units installed world-wide.



CONTROL PLUS ACCURACY IN MIXING, WITH MAXIMUM RELIABILITY

The bi-2 mixer is the most advanced technical solution for solventless adhesive mixing and metering, enabling the highest level of accuracy and quality for the lamination process.

This is achieved by means of the proven **lr.products** gear pumping technology, controlled by an industrial electronic PLC platform and a proprietary developed software.

AUTOFILL: OPTIONAL AUTOMATIC REFILLING

Increase productivity, no need to refill the mixer by hand, fully automates a previously tedious process.

It prevents the creation of a jelly skin on the surface of the adhesive because there is no moisture inside the component tank. The auto-fill works in a completely enclosed environment.

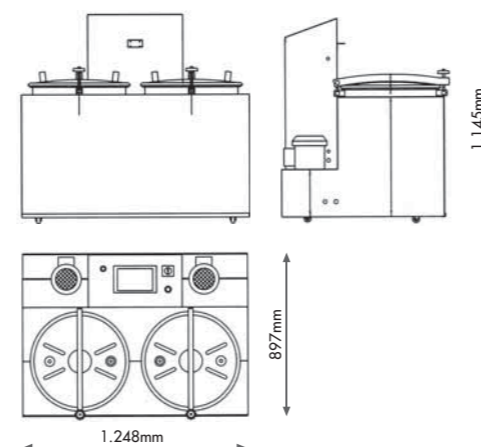

bi-2 mixer automatic refilling



AUTOFILL GRAV

- Automatic refilling by means of 2 additional valves
- Adhesive flows by means of gravity
- It works better with 1.000 kg adhesive containers
- Adhesive containers need to be placed on top of the mixer



AUTOFILL NEUMAT

- Automatic refilling by means of 2 additional pneumatic pumps
- Works better for 200 kg adhesive drums
- It allows the use of the drums on a vertical position
- No manipulation needed



AUTOFILL PUMP

- Automatic refilling by means of additional transfer gear pumps
- Remote refilling allowed, distance up to 50 meters aprox.
- Allows fully automatic refilling for several laminators
- Custom made solutions available

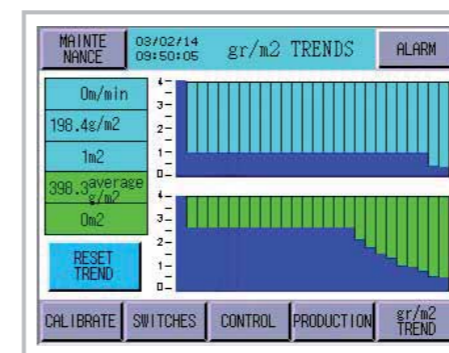
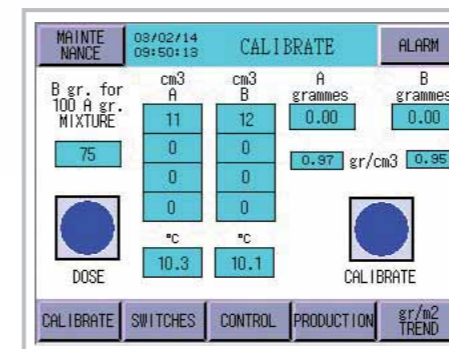

OUTSTANDING FEATURES

1 Unique in the market: calibration function

- The calibration function allows the system to calibrate according to the adhesive chosen.
- Once done, the unit accurately meters the exact amount of each component in weight ratio.

2 In line g/m² calculation function

- Once calibrated, the PLC makes a continuous calculation for the g/m².
- A graphic display shows the operator any deviation from the desired amount.

INCLUDED FEATURES

- High accuracy, easy to use and even easier to install
- MAN/AUTO, "clean" and "empty tanks" function
- Variable flow according to consumption
- Alarms and troubleshooting diagnostics
- Reports on consumption, output and g/m² coating
- Optimum temperature of adhesive maintained prior to production
- Can be installed in any laminator available in the market
- Totally problem free maintenance
- Independent temperature selection
- Double temperature control for higher security
- Permanent level control by means of ultrasonic sensors
- Stainless steel construction

USER FRIENDLY EQUIPMENT

- Replaceable static mixer on the mixing head
- Adhesive mixing and application just before the metering point
- Easy to install at set-up
- Stainless steel removable tanks
- Tool free, easy to clean and manipulate
- Portable; can be easily moved

Blocking valve as an optional



- Blocking valve for mixing thick adhesives.
- Recommended when using very thick adhesives, or adhesive systems with a very big difference in both component viscosities.
- It will prevent drop leaks from the mixer on the laminator.
- Independent blocking system for the 2 components.